

Propeller QuadRover Robot (#28195) or “QUADROVER”

The QUADROVER uses a Honda 2.5 HP 4-stroke engine to activate an hydraulic power system managed by the Propeller Control Board for the ultimate in customizable robots. There are twelve 5-volt-tolerant general-purpose Propeller I/O pins available, four free N-channel switches, and five available servo ports. The Propeller Control Board includes sockets for GPS, compass, and 3-axis accelerometer sensors (sold separately). The QuadRover is a heavy-duty robotics test-bed that is presently intended for research and development, including custom user-written programs and control systems.



Disclaimer of liability: Except as is expressly stated in the language herein pertaining to the Limited Warranty applicable to the QUADROVER, Parallax Inc. is not responsible for special, incidental, or consequential damages and injuries resulting from any other asserted breach of warranty, contract, or under any other legal theory, including lost profits, downtime, goodwill, damage to or replacement of equipment or property, or any costs of recovering, reprogramming, or reproducing any data stored in or used with Parallax products. Parallax Inc. is also not responsible for any personal injuries, including that to life and health, resulting from the customer’s application and use of any Parallax products. You, the

customer, assume full and unlimited responsibility for all customer Propeller QUADROVER robot applications and uses.

Warranty: Parallax Incorporated’s limited warranty provides to the original purchaser that the QUADROVER is free from defects in material and in the workmanship of assembly and Parallax agrees to repair or replace any defective product, other than those listed as consumables, free of charge within 90 days from the date of purchase.

This warranty is not transferable and does not cover damage resulting from other than defects in material or workmanship or damage caused by unreasonable use, including, but not limited to, the failure to provide proper and timely maintenance.

This warranty does NOT include set up or pre-delivery service and adjustments during the break-in period and beyond, such as carburetor adjustments. Parts not warranted are part of the normal maintenance responsibility of the customer, such as spark plugs, filters, lubricants, and starter cords. Products damaged from chemicals and alcohol blended fuels, lack of lubrication and timely maintenance, dirt, salt water corrosion, rust, varnish, paints, and moisture are not covered by this warranty.

The customer is responsible, at the customer’s expense, for arranging the delivery or shipment of the QUADROVER for warranty repairs and the subsequent pick up or delivery after warranty repairs have been made.

THIS LIMITED WARRANTY IS IN LIEU OF ALL OTHER EXPRESS WARRANTIES. ANY IMPLIED WARRANTY OF FITNESS FOR A PARTICULAR PURPOSE, MERCHANTABILITY OR OTHERWISE APPLICABLE TO THIS PRODUCT, SHALL BE LIMITED IN DURATION TO THE DURATION OF THIS LIMITED WARRANTY. PARALLAX INCORPORATED SHALL NOT BE LIABLE FOR ANY SPECIAL INCIDENTAL OR CONSEQUENTIAL DAMAGES.

SOME STATES DO NOT ALLOW LIMITATIONS ON HOW LONG AN IMPLIED WARRANTY LASTS, SO THE ABOVE LIMITATION MAY NOT APPLY TO YOU. SOME STATES DO NOT ALLOW THE EXCLUSION OR LIMITATION OF INCIDENTAL OR CONSEQUENTIAL DAMAGES, SO THE ABOVE LIMITATION OR EXCLUSION MAY NOT APPLY TO YOU. THIS WARRANTY GIVES YOU SPECIFIC LEGAL RIGHTS AND YOU MAY ALSO HAVE OTHER LEGAL RIGHTS WHICH VARY FROM STATE TO STATE.

Table of Contents

1.0 Safety Precautions	3	3.7. QUADROVER Layout	8
1.1. Description	3	3.8. Propeller Control Board Schematic.....	9
1.2. Technical Specifications	4	4.0 Setup Instructions	10
1.3. Applications.....	4	4.1. Supplies Needed	10
1.4. Packing List.....	4	4.2. Preparation	10
2.0 Hydraulic System.....	5	5.0 Operating Instructions	14
2.1. Hydraulic System Overview	5	5.1. Maintenance Instructions.....	14
2.2. Hydraulic Schematic.....	5	5.2. Additional Instructions	15
3.0 Electrical System	6	5.3. Throttle and Flow Control Precautions.....	15
3.1. Engine Electrical and Shutoff Electronics	6	5.4. Control Sequence	16
3.2. Propeller Control Board Electronics	6	6.0 Document Revision History.....	16
3.3. Ground Isolation	6	6.1. Changes for Version 1.1	16
3.4. Tachometer Input	7	6.2. Changes for Version 1.2.....	16
3.5. Propeller Control Board Connection Diagram...	7	6.3. Changes for Version 1.3.....	16
3.6. Terminal Block Connection Diagram.....	8		

1.0 SAFETY PRECAUTIONS

CAUTION: The customer/user must read and understand this entire document before attempting to use the Propeller QUADROVER robot. The QUADROVER is a heavy-duty robotics test-bed that is intended for customer research and development, including custom user-written programs and control systems. Because of its size and weight, an improperly controlled QUADROVER can cause damage to itself and to other property, as well as personal injury, including death. The QUADROVER employs a gasoline engine and hydraulic power system, both of which can create high temperatures and high hydraulic pressure. Proper care and safety precautions must be taken when working with these systems.

Please observe the following precautions:

- Parallax Inc. will issue changes to this manual to update its accuracy and apprise the customer of new procedures and design changes. It is the customer's responsibility to maintain an updated operating manual. Documentation revisions will be posted and available for download from the QUADROVER product page at www.parallax.com. Before using the QUADROVER, check for the latest documentation.
- When developing and testing programs and applications with the QUADROVER, the robot should be elevated and firmly mounted on a platform in such a way that the wheels do not touch the ground and vibrations will not cause the QUADROVER to break free.
- The QUADROVER must be safely operated in a controlled area free from people, animals, and property that could be damaged.
- Proper safety equipment must be worn while working on the QUADROVER.
- An engine kill-switch pull string and tether have been provided. The tether must be attached to the ring on the pull-string for use as an emergency cut off in the event of an unintended loss of control.
- It is the responsibility of the customer and any designated operator to know and comply with all state and local laws and regulations applicable to the operation of gas-engine equipment, including, but not limited to, requirements for spark arrestors and any restrictions for operating gas-engine vehicles on public property or streets.
- It is the customer's and the user's responsibility to obtain and properly store all Material Safety Data Sheets for the gasoline, engine oil, and hydraulic oil used.
- Parallax Inc. cannot be held responsible for any harm or injury that may occur due to improper, unsafe, or uncontrolled operation of the QUADROVER.

1.1. Description

The Parallax QUADROVER is an all-terrain, gasoline-powered hydraulically driven robotic test-bed That has not been tested by Parallax with components carried or added to the QUADROVER chassis. The QUADROVER drive train is a 4WD drive skid-steer system, which operates most efficiently on gravel and dirt surfaces. The skid-steer system is less efficient at turning on grass and pavement, but top speeds are not affected.

The QUADROVER's gasoline engine provides longer operating durations and higher energy density and power than a battery powered electric motor. This is necessary for a larger robot based on skid-steering and allows extended use by refueling when distant from an electric recharging source.

Parallax provides sample Propeller code for radio-controlled use. Using a QUADROVER for autonomous outdoor robotics projects requires further code development and modification by the user with particular attention paid to safety precautions. The QUADROVER's size and mass may pose considerable risk to humans, property, and the environment if not used responsibly. All additions, changes and modifications

done to the QUADROVER will be entirely at the customer's own risk. Parallax is available to answer technical questions relative to the QUADROVER but will not advise as to loading of the QUADROVER chassis with customer modifications.

1.2. Technical Specifications

- Dimensions: 29 x 19 x 23 in. (73 x 48 x 58 cm)
- Wheelbase: 16.0 in. (40 cm)
- Ground Clearance: 3 in. (7.62 cm) front; 2 in. (5 cm) rear (disc brake)
- Maximum Speed: 12 miles per hour (19.2 KPH)
- Fuel Capacity: 0.81 US qt (0.77 L)
- Dry Weight: 89 lbs (40.4 kilograms)

DXF formatted drawings of specific parts and systems are available from the Parallax QUADROVER product page at www.parallax.com. These drawings include replacement parts, electrical and mechanical diagrams, and a complete bill of materials.

1.3. Applications

Some anticipated outdoor applications for the QUADROVER include:

- GPS-based autonomous navigation
- Semi-autonomous R/C control for task-oriented projects
- Municipal law enforcement, bomb removal, etc.
- Hobby projects
- Entertainment and sporting events
- Unmanned transportation

1.4. Packing List

The following items should be included in your QUADROVER packing crate. If any are missing, please contact Parallax via email or telephone:

- Assembled QUADROVER Robot with the Propeller Control Board installed
- Roll-cage assembly with mounting hardware
 - (1) roll-cage
 - (2) mounting screws
 - (4) nylon washers
 - (2) steel washers
 - (2) locking nuts
 - (2) cotter pins
- Gas cap
- Antenna support rod
- 1/16 inch Hex key
- Kill-switch tether cord with swivel clip
- Engine manual
- R/C radio transmitter/receiver system
- Four 14-inch female/female servo extension cables
- Prop Plug programming tool
- USB A to Mini-B cable

Replacement parts for the QUADROVER are available directly through Parallax, via one of our suppliers. For a detailed list of the robot's components, please visit the QUADROVER product page at www.parallax.com.

2.0 HYDRAULIC SYSTEM

2.1. Hydraulic System Overview

The QUADROVER's 2.5 HP 4-stroke engine is coupled, through a clutch, to a hydraulic pump. The pump's output is split between two solenoid-actuated flow-cutoff valves to enable or disable flow to either the left or right motor. The output of each of these valves is then connected through solenoid-actuated flow-reverse valves to control the direction of wheel rotation. The hydraulic oil is then returned to the hydraulic reservoir for reuse. The engine throttle is proportionally actuated by a Parallax standard servo. Increasing the throttle and engine RPM creates increases flow and pressure through the hydraulic system, resulting in higher speed.

Hydraulic oil pressure in the QUADROVER varies as the viscosity of the oil changes. Hot oil (above 165 °F) could cause pump cavitations, excessive noise and wear to the motors. While the rating of the hydraulic system is 2,800 PSI (continuous) and the pump is capable of developing pressure to 2,300 PSI, this is generally not possible with the engine supplied in the QUADROVER. During tests, maximum pressure achieved was between 900 to 1,000 PSI at 100 °F.

Temporary surge pressures up to 4,000 PSI are possible but unlikely. Surge pressures can be caused by a forward movement which is quickly reversed without first braking and stopping the robot. Please follow all precautions in section 5.3 and operating sequence instructions in section 5.4. Pressure also varies with temperature. In cold weather oil viscosity is higher, causing more strain on the gas engine. Alternative oils may be chosen for very cold or extremely hot climates.

2.2. Hydraulic Schematic

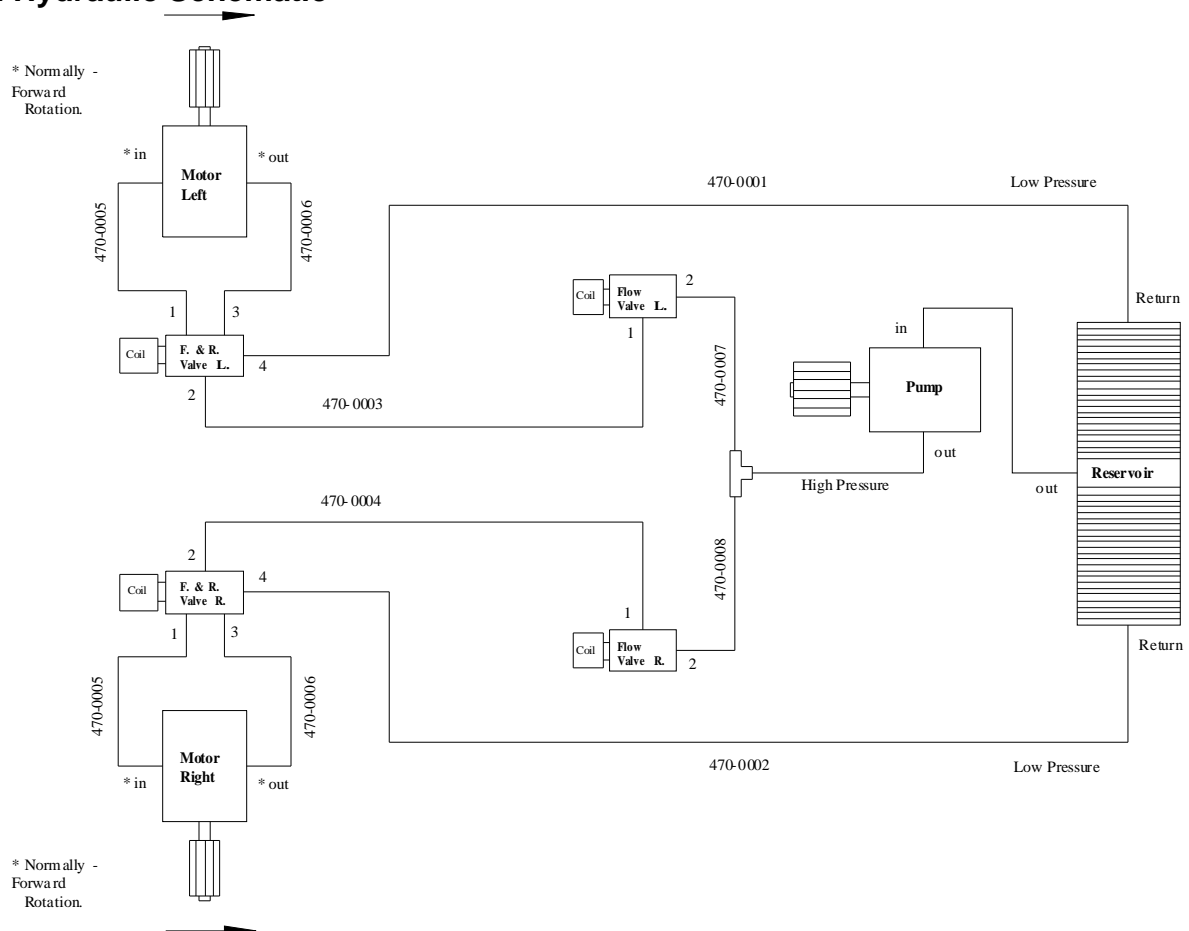

3.0 ELECTRICAL SYSTEM

3.1. Engine Electrical and Shutoff Electronics

The QUADROVER's main electrical power supply is a Power-Sonic PSH-1280F2-FR (UL94 V-0 flame retardant) 12 volt 8.5 amp-hour lead-acid battery. This battery provides power to:

- Propeller Control Board
- Three servos (throttle, left and right brakes)
- Four solenoid-controlled valves (two flow-cutoff valves and two flow-reverse valves)

The QUADROVER's hydraulic system also generates significant heat. This hydraulic pump is fitted with a 140° F (60° C) shutoff sensor. If the hydraulic oil exceeds this temperature, a thermal switch will ground the engine's spark plug, causing the engine to shut off. The hydraulic reservoir is also equipped with a visual sensor (no electrical connection) to show approximate temperature of the hydraulic oil.

3.2. Propeller Control Board Electronics

Since the various controls for the QUADROVER would be difficult to control manually, a Propeller Control Board (Parallax stock #28205) is included to properly operate the QUADROVER. Before programming the Propeller Control Board, download the example code from the QUADROVER product page at www.parallax.com and carefully read through and follow the included documentation. It is especially important that proper calibration is performed and all safety guidelines are followed.

The Propeller Control Board includes the following features:

- Propeller P8X32A-Q44 Microcontroller
- 64 KB EEPROM (32 KB used for program storage)
- Tachometer input
- (8) N-Channel MOSFET driven output ports (4 used by the QUADROVER)
- (8) servo output ports (3 used by the QUADROVER)
- (12) auxiliary I/O connections with 10K Ω series protection resistors
- Three-position power switch (on, Propeller on and servos off, off)
- Mounting locations for the following Parallax sensors (not included):
 - GPS Receiver (#28146)
 - Hitachi H48C 3-Axis Accelerometer (#28026)
 - Hitachi HM55B Compass Module (#29123)

3.3. Ground Isolation

The Propeller Control Board's electrical ground is isolated from the chassis ground to reduce the likelihood of damage in the event of an electrical short. The QUADROVER's solenoids are connected between the positive battery terminal and N-channel MOSFETs. If the negative terminal of a solenoid is accidentally connected to an electrical ground, the solenoid will activate. If modifications are performed that require the Propeller Control Board's electrical ground be connected to the chassis ground, extra precautions should be taken to ensure that the solenoids do not make electrical contact with the Propeller Control Board through any chassis ground.

3.4. Tachometer Input

The Propeller Control Board includes a tachometer input that can be connected to the magneto of an engine to determine its rotation speed. To be functional, the tachometer input requires the Propeller Control Board's electrical ground to be connected to the QUADROVER chassis ground. See the precautions in section 3.3 before connecting the tachometer.

3.5. Propeller Control Board Connection Diagram

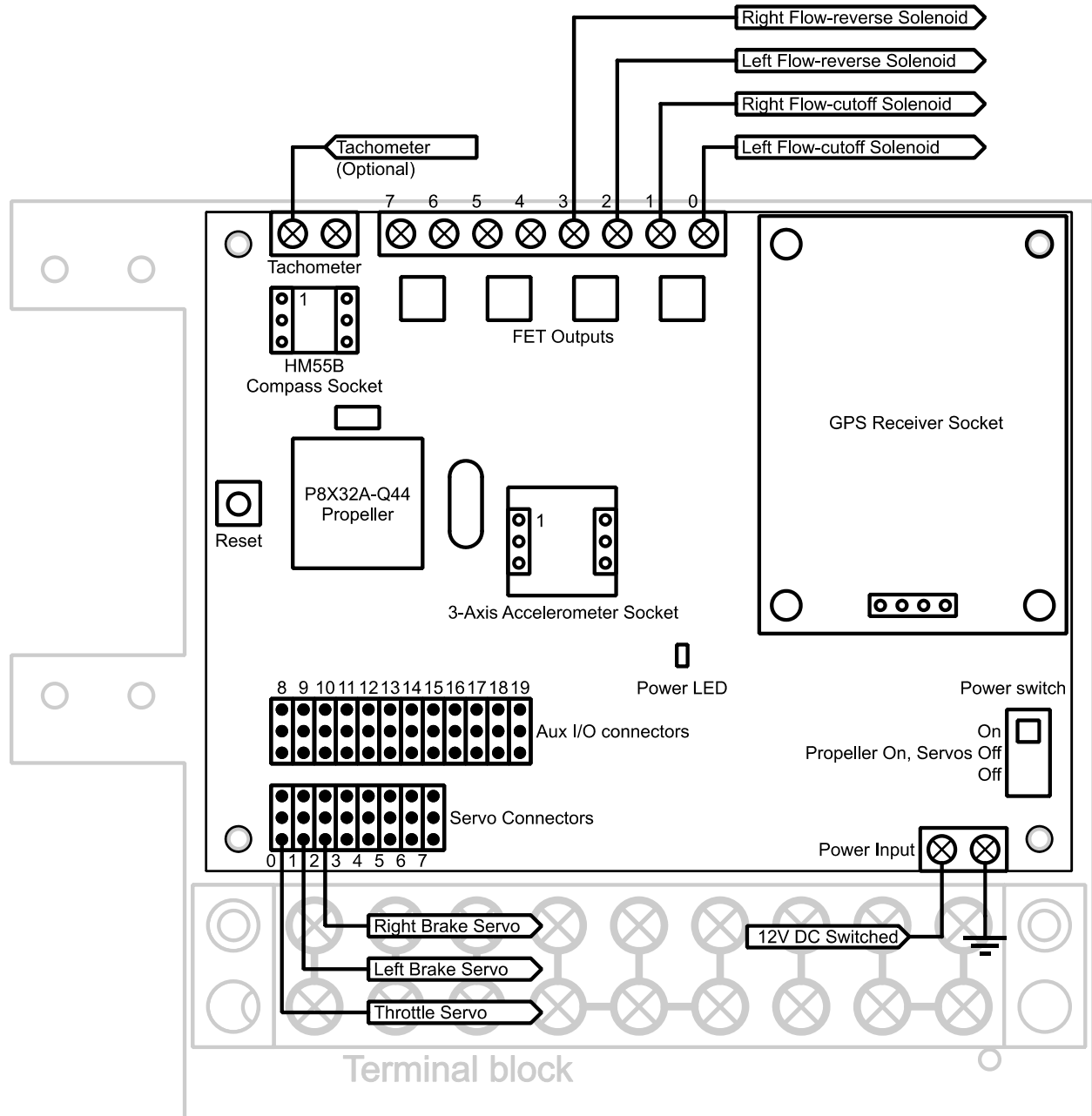

3.6. Terminal Block Connection Diagram

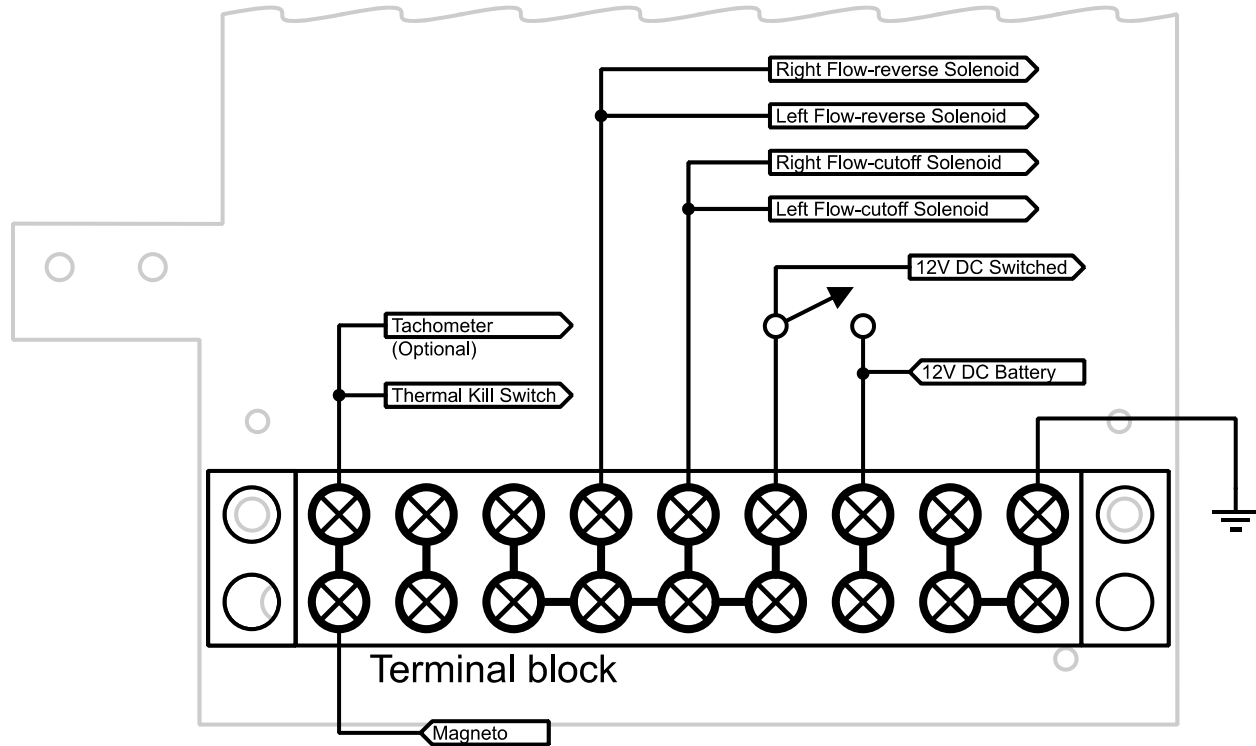

3.7. QUADROVER Layout

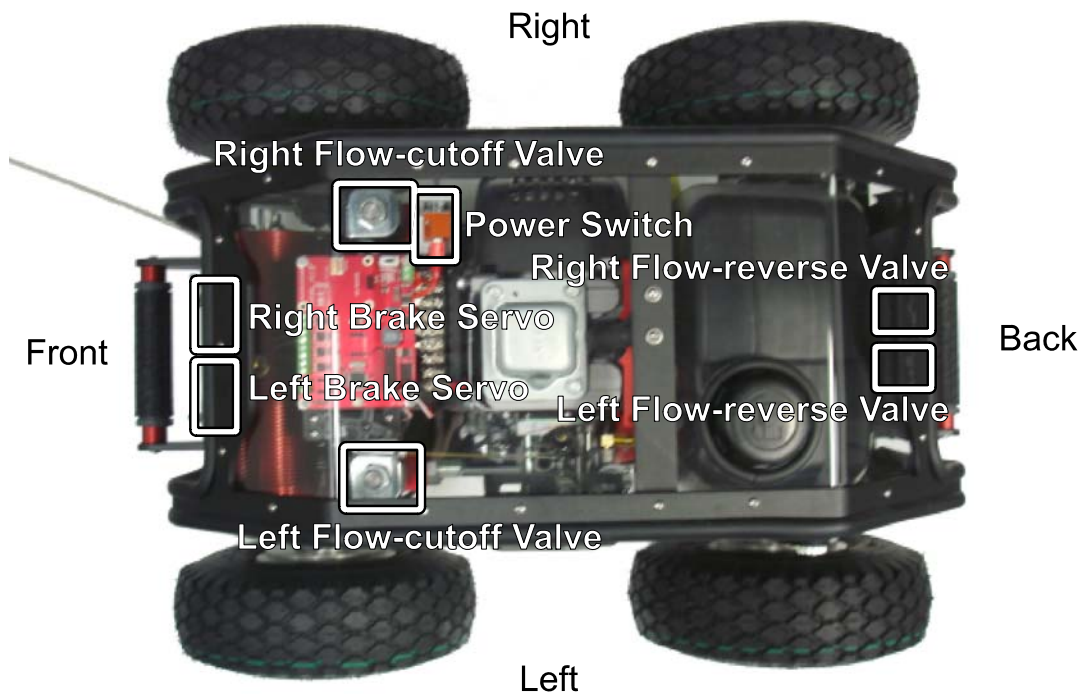

3.8. Propeller Control Board Schematic

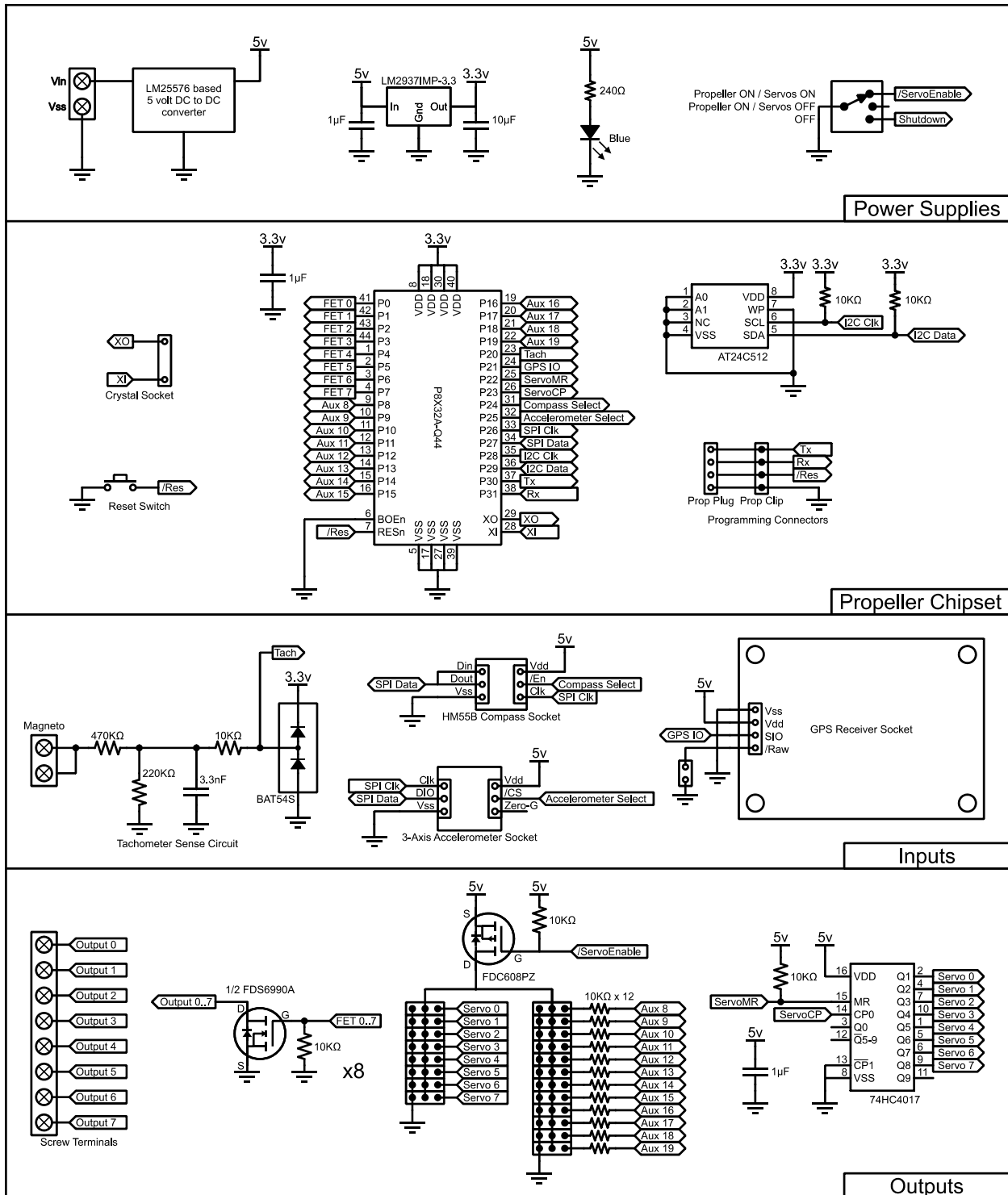

Propeller Control Board

Rev A Schematic

4.0 SETUP INSTRUCTIONS

Before performing any part of the following, thoroughly read this document and follow all safety precautions.

4.1. Supplies Needed

The following supplies, tools and equipment are needed to prepare a QUADROVER for its initial operation:

- Charging system capable of charging a 12 V 8.5 Amp-hour battery
- Hydraulic oil: ISO-46 (3 cups; 0.71 L). USE ONLY ISO APPROVED HYDRAULIC OIL.
- Engine oil: SAE 10-20 motor oil (1 1/8 cups). USE ONLY SAE APPROVED MOTOR OIL.
- Unleaded Gasoline. USE ONLY UNLEADED GASOLINE.
- Funnel
- Safety glasses
- Standard hex wrench set including 1/16th inch and 3/32nd inch sizes
- 11/16th inch wrench
- A strong, stable platform that the QUADROVER can be mounted to during programming and testing so that its wheels do not touch anything and it does not vibrate loose
- Personal computer running Windows 2K/XP/Vista with an available USB port and an Internet connection for obtaining the Propeller Tool software from www.parallax.com.

4.2. Preparation

The following steps must be performed to prepare the QUADROVER for operation:

1. Check for loose or missing screws, frayed cables or wires, frayed kill-switch cord or loose knots, and loose connections to the Propeller Control Board. Repair any noted defects before use.
2. Fully charge and then connect the included 12 V battery:
 - a. The battery does not have to be removed from the QUADROVER during charging.
 - b. When connecting the charged battery, be sure that the fuse casing and leads do not contact the drive belt.
3. Mount the QUADROVER on a stable, raised platform so that the wheels are not in contact with anything.
4. Read the Honda Engine Manual, and follow those directions for adding oil to the engine. The oil cap is shown in the picture below.
5. Attach the kill-switch tether to the ring (shown below) and secure the tether so it is clear of the wheels.

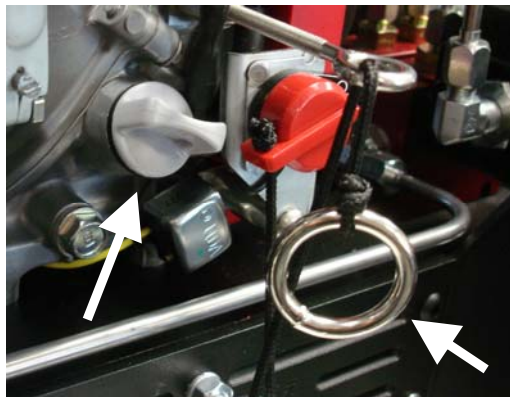

6. (Optional) Install the support rod, if needed to support an antenna, flag, or similar item:
 - a. Using the included 1/16th inch hex wrench, loosen the set screw as indicated in the image shown below.
 - b. Insert the support rod into the hole provided.
 - c. Tighten the set screw.

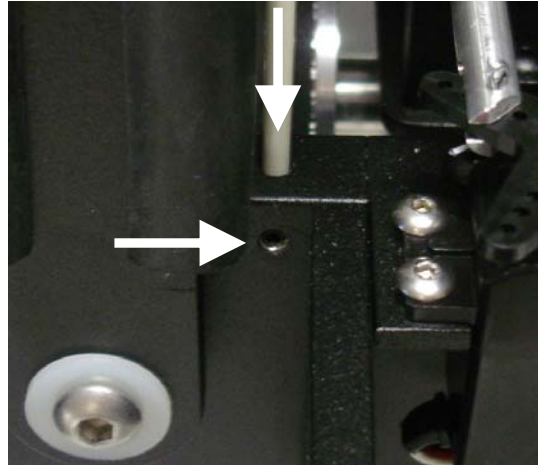

7. Add hydraulic oil to the hydraulic reservoir and bleed all air out of the hydraulic lines:
 - a. The QUADROVER must still be mounted on a stable, raised platform such that the wheels do not contact anything.
 - b. Using an 11/16th wrench, remove the pressure relief valve, indicated below, from the top of the hydraulic reservoir.
 - c. Insert a clean, dry funnel into the fill hole.

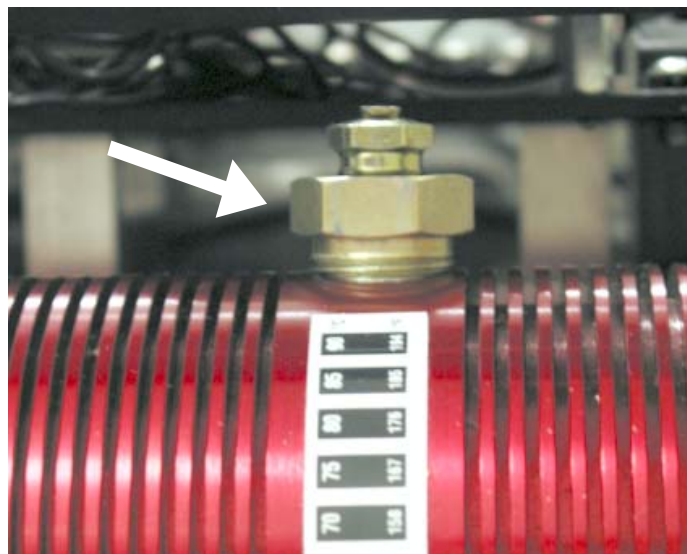

- d. Locate the hydraulic pump under the hydraulic reservoir.
- e. While continuously hand-rotating the engine clutch (connected by a belt to the hydraulic pump) in a clockwise direction (as viewed from the rear of the QUADROVER), slowly add 10-20 multi-viscosity hydraulic oil (ISO46) to the reservoir. **USE ONLY SAE/ISO APPROVED HYDRAULIC OIL.**

- f. Periodically remove the funnel and look into the hole to check for rising air bubbles in the hydraulic oil.
- g. Once the tires begin to rotate, they can be manually rotated in lieu of manipulating the clutch, alternating between the left and right sides, instead of the engine clutch while continuing to add the hydraulic oil.
- h. As air is worked out of the lines, the oil level in the reservoir will start to fall. Do not let the reservoir fall below the hydraulic oil return (dashed line in the picture below), but do not fill it higher than the solid line.
- i. Continue to rotate the wheels and watch for air bubbles. Once the hydraulic reservoir is free of air bubbles, the wheels and pump no longer need to be manually rotated.
- j. Using a 3/32nd inch hex key, remove the screw and o-ring at the side of the reservoir as indicated by the arrow below.
- k. Fill the reservoir to the bottom of the screw hole as indicated by the line below. **DO NOT OVERFILL THE HYDRAULIC RESERVOIR.** If the reservoir is filled above the height of the screw hole, the QUADROVER will not function properly and serious harm or damage may occur.

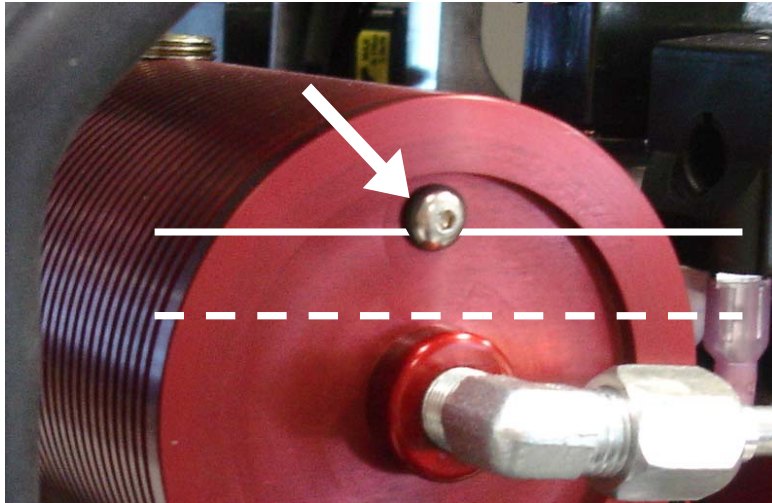

- l. Reinstall the screw and o-ring and tighten by hand until snug; do not over-tighten.
 - m. Replace the pressure relief valve.
 - n. With the QUADROVER still firmly mounted on its platform, follow the instructions in the Honda Engine manual to start the engine. Run the engine for a few minutes, let it cool off, then check the hydraulic oil level. If the level has dropped, remove the pressure-relief valve and repeat steps j through m.
8. Install the roll-cage:
- a. Attach the roll-cage to the two pegs (like the one shown) on the left side of the QuadRover.

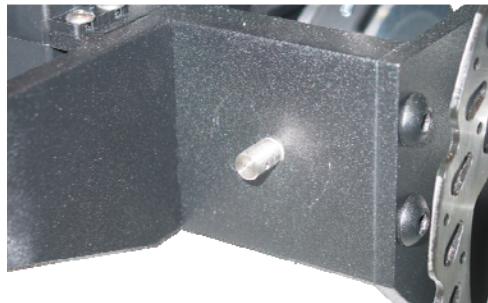

- b. Attach a cotter pin to each peg.
- c. Using the mounting screws and nylon washers, in the arrangement shown, screw the right front and back sides of the roll-cage into the QuadRover chassis.

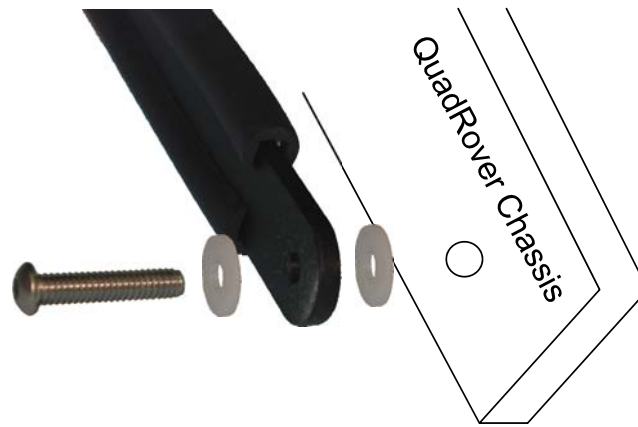

- d. Attach the metal washer and locking nuts to the right front and back sides of the roll-cage, as shown.

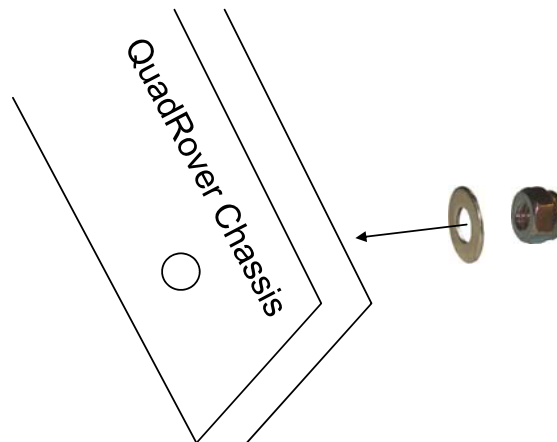

- e. Once the roll-cage has been mounted it should match the following image, when viewed from below.

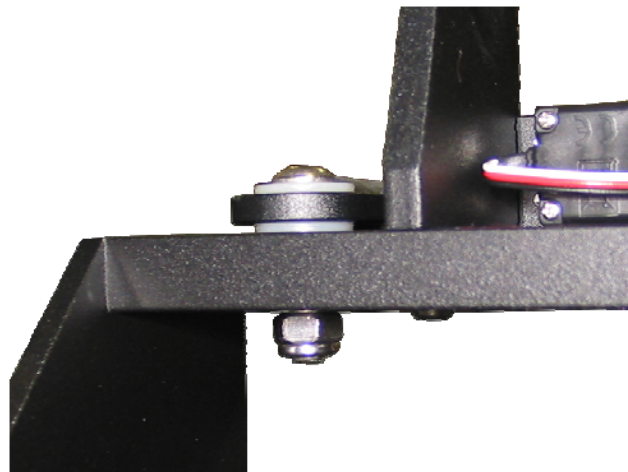

9. Connect the fuel line from the gas tank on the roll cage to the engine.

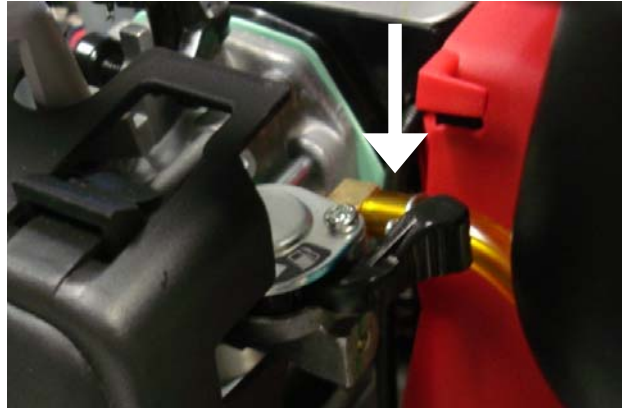

10. Following the directions in the Honda Engine Manual, add 0.81 quart (0.77 L) of unleaded gasoline to the engine's fuel tank (located at the top of the robot) and screw on the gas cap.
11. Download the example code and instructions available on the QUADROVER product page at www.parallax.com (Search for 28195).
12. Follow all of the instructions, including calibration, provided with the example code.

5.0 OPERATING INSTRUCTIONS

5.1. Maintenance Instructions

1. Drain and replace the hydraulic oil after the first 5 hours of use.
2. After the first replacement of the hydraulic oil, check the hydraulic oil level periodically (every 10 to 20 hours of operation).
3. Refer to the Honda Engine manual for engine maintenance instructions, including the required frequency of engine oil changes. There is a low oil sensor on the engine; if the oil level drops too low, the engine will shut off and will not start.
4. Before each use, check engine oil levels and check for hydraulic oil leaks. Restore fluids to required levels before use.
5. Before each use, check for loose or missing screws, frayed cables or wires, frayed kill-switch cord or loose knots, and loose connections to the Propeller Control Board. Repair before use.
6. If the tire pressure needs to be adjusted, remove the plug from the side of the hub, install a valve stem extension, and adjust the tire pressure. After the tire pressure has been adjusted, remove the valve stem extension and replace the plug.
7. When storing or transporting the QUADROVER, first disconnect the battery or remove the fuse.

5.2. Additional Instructions

1. DO NOT OVERRIDE THE ENGINE GOVERNOR: This will damage the engine and will void the warranty.
2. DO NOT RUN THE ENGINE FASTER THAN 7.500 RPM (maximum). This will also void the warranty.
3. When adding equipment, mount it directly to the chassis and not to the roll-cage. Only small sensors and other items of minimal weight can be mounted to the roll cage. The roll-cage must be able to vibrate freely or it may be damaged.
4. When transporting the QUADROVER, it can be pushed or pulled in a forward direction, but care should be taken to not make rapid accelerations, or pressure may build up in the hydraulic reservoir, and the pressure relief valve may vent hydraulic oil.
5. If, at any time, the pressure relief valve on the hydraulic reservoir vents oil, wait for the reservoir to cool, then check the hydraulic oil level.

5.3. Throttle and Flow Control Precautions

For each individual side, the front and rear wheels are connected by a drive belt. Servo-driven disk brakes can be individually applied to either side of the QUADROVER. Much like an automobile, brakes may be applied at anytime during operation. The flow-reverse valves in the hydraulic system are analogous to the reverse gear in a traditional automobile. Care should be taken to "shift into reverse" only when it is appropriate.

Always follow these precautions while controlling the QUADROVER:

1. Do not apply the throttle while the brakes are applied; the engine should be on idle while braking.
2. If the flow-cutoff valve has been used to disengage hydraulic flow to one side of the QUADROVER, brakes can be applied to that side, but should be applied gradually. Sudden braking of a single side of the QUADROVER while it is in motion may cause the QUADROVER to skid and lose control.
3. Sudden changes in throttle can cause surges in hydraulic pressure; adjust the throttle gradually.
4. Do not engage the flow-reverse valves unless the QUADROVER is stopped and the engine is idle. **ENGAGING THE FLOW-REVERSE VALVES WHILE THE ENGINE THROTTLE IS APPLIED OR THE QUADROVER IS IN MOTION CAN RESULT IN SERIOUS DAMAGE.**
5. **DO NOT ENGAGE BOTH FLOW-CUTOFF VALVES SIMULTANEOUSLY.** Hydraulic fluid must be able to flow through at least one side of the QUADROVER at all times.

5.4. Control Sequence

The following control sequences are used by the control board to drive the QUADROVER:

Direction of Travel	Control Sequence
Driving forward	Increase gas engine throttle proportional to the desired speed.
Driving in reverse	<ol style="list-style-type: none">1. Decrease gas throttle servo to idle.2. Wait for the QUADROVER to come to a full stop.3. Engage both flow-reverse valves.4. Increase gas throttle servo proportional to the desired speed.5. Do not disengage the flow-reverse valves while driving in reverse.
Returning to forward	<ol style="list-style-type: none">6. Decrease gas throttle servo to idle.7. Wait for the QUADROVER to come to a full stop.8. Disengage both flow-reverse valves.9. Increase gas throttle servo proportional to the desired speed.
Turning in place	<ol style="list-style-type: none">1. Decrease gas throttle servo to idle.2. Wait for the QUADROVER to come to a full stop.3. Engage the reversing solenoid on the side of the QUADROVER that it will be turning toward.4. Increase gas throttle servo proportional to desired speed.
Turning while driving	<ol style="list-style-type: none">1. Engage the cutoff solenoid on the side of the QUADROVER that it will be turning toward.2. Gradually engage the brake, located on the same side of the QUADROVER, proportional to the desired turn rate.

Please see the example code available for download from the Propeller QUADROVER product page at www.parallax.com.

6.0 DOCUMENT REVISION HISTORY

6.1. Changes for Version 1.1

Section 1.0 Safety Precautions: Introductory paragraph modified; additional bullet item regarding material safety data sheets added. Section temp 6.0 Document Revision History added.

6.2. Changes for Version 1.2

Change to section 1.2 Technical Specifications: dimensions corrected. Additions to Section 1.4 Packing List: R/C radio controller system; four 14-inch servo extension cables. Former Section 4.0 split into sections 4.0 Setup Instructions and 5.0 Operating Instructions. Section 4.1 Supplies Needed list has changed; please review. Additions to 5.1 Maintenance Instructions: item 6 regarding tire pressure adjustment; item 7 regarding storage. Addition to 5.2 Additional Instructions: item 3 regarding the roll-cage.

6.3. Changes for Version 1.3

Introduction and Disclaimer of Liability updated. Warranty added. Section 1.0 Safety Precautions updated. Section 1.1 Description updated. Section 1.4 Packing List: added Prop Plug and USB cable. Changes in section 4.2 Preparation: Order of steps has changed (gas is added later in the procedure). Instructions updated to reflect replacement of hydraulic reservoir's plug with pressure relief valve. Instructions added for the installation of the roll-cage and connection of the fuel line. Section 5.2 Additional Instructions: added new instructions regarding the pressure relief valve. Minor editorial changes throughout.